



SHOWER
POWER
BOOSTER

INLINE MICRO PUMP



Information Manual
www.showerpowerbooster.co.uk

Boosts water flow to any shower, tap & so much more!





THE INVENTOR | ALAN WRIGHT

The Shower Power Booster was invented by Chartered Civil Engineer and hydraulics expert Alan Wright, who has worked in municipal water for 30 years, 25 of which were at Anglian Water. Over the years Alan has designed and worked on many water projects and his expertise are often sought to provide solutions to complex problems.

In his early years, as a reservoir inspector, Alan was impressed by the superb work of Victorian engineers who understood the physics of water and made things happen without complex electronics. He discovered that the Victorians simply allowed the water to do what it wanted to do and not force it to do something it does not want to do! It is the mix of physics and simplicity which Alan has applied to his invention - the Shower Power Booster.

A result of careful and correct application of science, the Shower Power Booster uses innovative and unique patented technology which can transform your showering experience or enhance a dribbly tap, giving the same effect felt from a pump 20 times bigger.

The Inventor.....	2
Contents.....	3
Introduction.....	4 - 5
Product Range.....	6
Technical Specifications.....	7
3 Step Installation.....	8
Wiring Diagrams.....	9
Installation Instructions - Gravity System	10 - 11
Installation Instructions - Mixed System	12
Installation Instructions - Combination Boilers	13
Installation Instructions - Electric Showers & Radiators	14
Flexible Installation.....	15
Installation Tips & Troubleshooting.....	16 - 17
Flowflex Components LTD.....	18 - 19



The Shower Power Booster (SP2B) is an award winning, innovative product, celebrated for its power versus size properties, winning Best Water Innovation by Imperial College London 2012.

WRAS approved and fully factory tested, the pump comes with a 2 year warranty which can be extended to 3 years.

Designed as a retro-fit booster, it uses a safe 12-volt brushless motor which is highly efficient, fully waterproof and has low friction long-life bearings.

It is highly efficient when delivering volumes of water of up to 6.5 litres per minute to a traditional shower head or tap and it can deliver up to 9 litres of blended water for rain showers and bath taps.

The SP2B does not restrict flow and it automatically deactivates itself in the event of high flow rates or in a power cut, so your original flow is fully restored.

The Shower Power Booster has been installed in thousands of homes across the UK and beyond since 2012 with excellent customer satisfaction.

It comes with a 30 day money back return period so we encourage customers to trial the product and guarantee a refund if you are not fully satisfied.

ShowerPowerBooster pumps have been manufactured under licence in the UK by Flowflex Components LTD since 2013.

Shower Power Booster appeared on Dragons Den in 2013 search on YouTube:

***'Shower Power Booster
Dragons Den'***



Rated 'Excellent' on  Trustpilot Over 1,000 Reviews

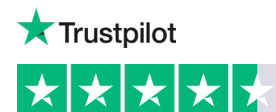

SINGLE PUMPS

**SP2B
AUTOMATIC SHOWER POWER BOOSTER**



**SP1
MANUAL SHOWER POWER BOOSTER**



Both Automatic & Manual Shower Power Boosters are supplied with:
 ✓ 3 Amp Transformer ✓ 22mm to 15mm Reducing Sets

DOUBLE PUMP PACKS

**SP22S
TWO AUTOMATIC PUMPS**



**SP21S
AUTO & MANUAL PUMPS**



Double Pump Packs are supplied with:
 ✓ 5 Amp Transformer ✓ 22mm to 15mm Reducing Sets
 ✓ Cables to link Two Pumps together

UPGRADE PUMPS

**SP2U
AUTOMATIC PUMP UPGRADE**



**SP1U
MANUAL PUMP UPGRADE**



An Upgrade Pump adds a Second Pump to your existing setup and are supplied with:
 ✓ 22mm to 15mm Reducing Sets ✓ Cables to link Two Pumps together
 ✗ No Transformer, both pumps run from your existing Transformer

GENERAL	2 Year Warranty (3 years with SPB Ultimate Care Pack)	
	30 Day Return Policy	
	WRAS Approval - 2002802	
FEATURES	Pump Type	Centrifugal with Brushless Motor
	Inlet Filter	✓
	Dry run protection	✓
	Waterproof	✓
MATERIALS	Body	Brass - BS6282-5
	Pump	Plastic
PHYSICAL	Length	150mm
	Width	45mm
	Height	125mm
	Weight	625g
	Pump Connection	22mm or 15mm Compression
	PERFORMANCE	Maximum Head
	Typical Output	5 L/Min @ 3.2m
	Max Sustained Pressure	4 Bars
	Max Sustained Temperature	85°C
	Min Flow Rate	1.5 L/Min
	Max Flow Rate	9 L/Min
ELECTRICAL	Transformer	12 Volt 3 or 5 Amp Transformer
	Input	100 - 240 Volts 50/60Hz
	Output	12 Volts DC
	Power Consumption	12.6 Watts @ 5 L/Min
	Fuse Rating	3 Amp
	Power Cable	3 Pin Plug with 1m AC Cable Male DC Plug with 1m DC Cable

IMPORTANT: DO NOT ADJUST THE MOTOR NUTS. THESE ARE FACTORY SET TENSIONS.

All pumps are tested before shipping but we invite you to carry out pre-fitting checks:

- ✓ Plug in the transformer and you will get a constant blue light.
- ✓ When installed a flashing blue light will indicate a detected flow and the pump is running.

You can check the flow switch yourself by visiting YouTube and search:

'Shower Power Booster - Flow Switch Check'

If you do not have 1.5 litres per minute of flow then the pump will not automatically kick in.

- ✓ You can bypass the flow switch by plugging the transformer directly into the white motor.
- ✓ You can then operate the pump by turning the power on and off.
- ✓ You can use the plug, a radio remote, or wire into the lighting circuit to activate the pump.

3 STEP INSTALLATION

A Shower Power Booster can be fitted in most places enabling you to install wherever is most convenient. Pumps are supplied with everything you need to install on either 22mm or 15mm pipe and it takes just 3 simple steps to install:

STEP 1 - Select location for pump & isolate the pipe

The diagrams on the following pages suggest where is best to install the pump for specific applications. Please ensure that the pipework is isolated and free from water before cutting the pipe.

The Shower Power Booster limits the amount of water taken from the hot water cylinder and can only pump up to 9 litres a minute. Shower Power Boosters do not pull in air and there is no need for a Surrey or Essex Flange and no need to drain the hot water cylinder or cold water tank.

STEP 2 - Remove 115mm of pipe, insert the pump & tighten the compression joints.



- ✗ Do not hold the white motor when installing.
- ✓ Pumps can be fitted unsupported on existing pipework.
- ✓ Pumps can be fitted at any angle or orientation.
- ✓ Identify pipe size and use Reducing Sets if required.
- ❗ For 3/4" Imperial Pipe use 3/4" Imperial Olives .
- ❗ Inserts must be used when installing on plastic PEX pipe.
- ❗ If there is little play in the pipes use Compression Slip Couplings, which can be used to enable easy fitting.
- ❗ Do not use PTFE Tape on the screw threads.
On our website search:
'How To Prevent ShowerPowerBooster Joints Leaking'

STEP 3 - Connect transformer cable to the pump and to a power supply.



Once connected and turned on the LED light on an SP2B will indicate the status of the pump:

- Constant LED light** = Pump has power
- Fast flashing light** = Pump has detected water flow and is running
- Slow flashing light** = Transformer Fault or power protection tripping in and out

Please note: If you have two pumps connected the LED on one pump may shine blue for flash intermittently while the LED on the other pump may continuously flash rapidly - both pumps will be running. This is because the flow rate in one pump is less than 1.5 Litres a minute.

Shower Power Booster pumps can be installed without the need for an electrician. They run off a 12-volt power supply, which allows you to install in bathrooms, where traditional 240 volt pumps would not be allowed.

The transformer can be plugged into the nearest convenient 3-pin socket. You can access sockets up to 15m away from the pump by using our extension cables. Pumps, which only need 15 watts of power, can also run off an electric light circuit.



SP2B - A SINGLE AUTOMATIC PUMP

Connect the Female Socket on the chrome body on pump to the Male Connector on the Transformer

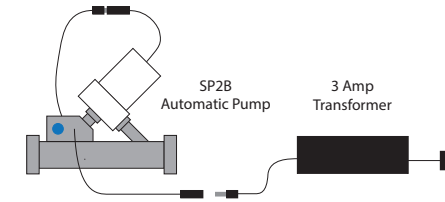

SP22S - TWO AUTOMATIC PUMPS (or SP2B and SP2U Upgrade Pump)

Balanced Flow: Boost both Hot & Cold Gravity Feeds

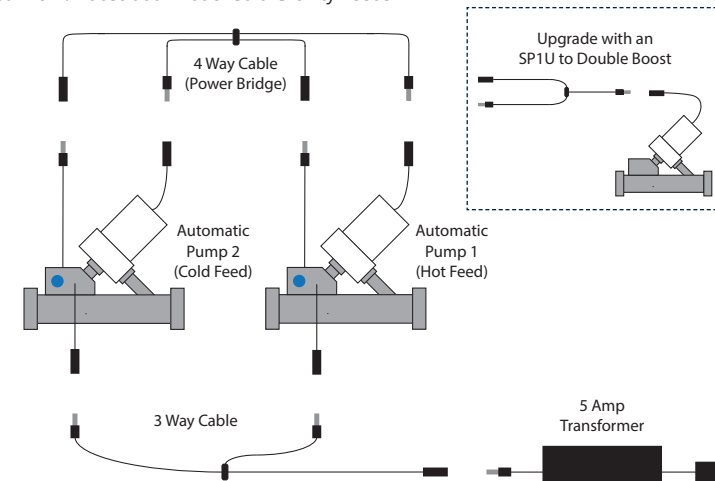

SP21S - ONE AUTOMATIC & ONE MANUAL PUMP (or SP2B & SP1U Upgrade Pump)

Double Boost: Two Pumps on Hot or Cold Feed provides a Double Boost

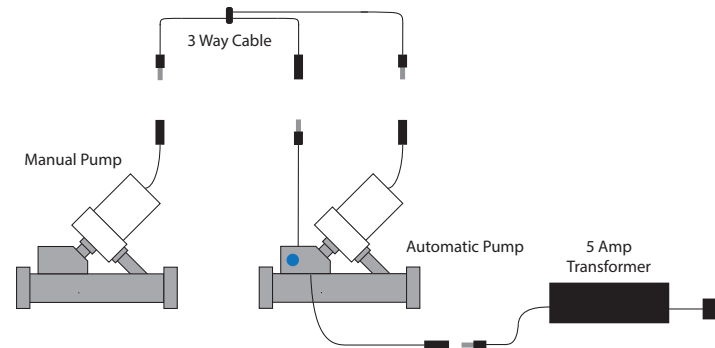

WHOLE HOUSE SOLUTION

For gravity systems, our whole house solution is the most popular choice. Installing a pump next to the hot water cylinder, but after the vent pipe, will boost the flow rate for every tap, shower & application in the house.

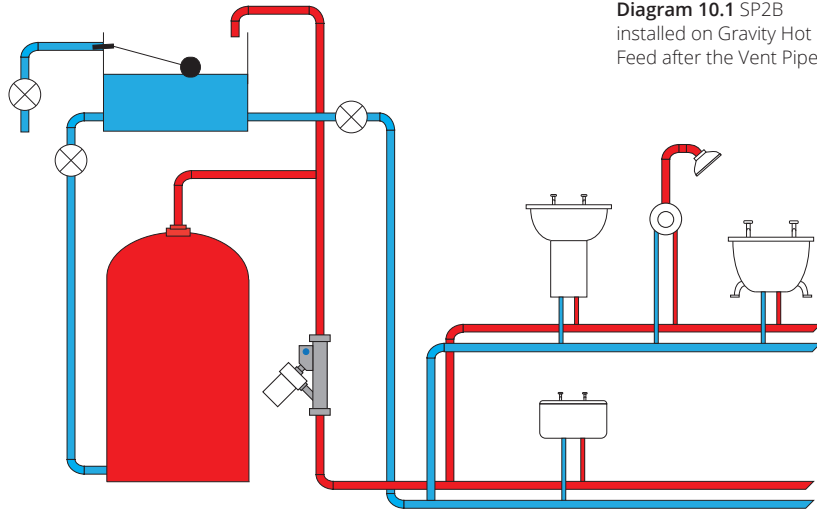

Diagram 10.1 SP2B installed on Gravity Hot Feed after the Vent Pipe.

PROTECTED FLOW SOLUTION

Sometimes there is just one tap, shower or application which is letting you down with poor flow rates & low pressure. The Shower Power Booster does not cavitate so you are able to install it on the feed which only supplies a specific tap or shower. This will not only improve the flow for the specific outlet, it will also maintain the flow even if other taps are being used in the home.

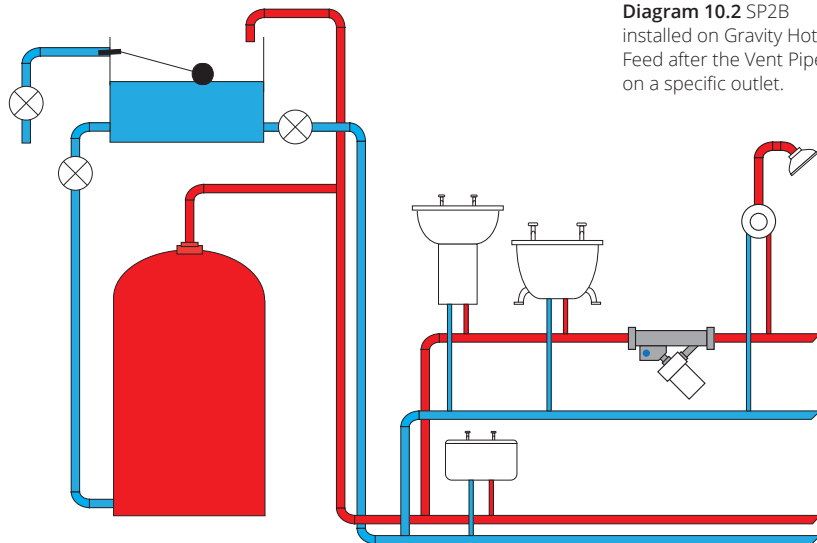

Diagram 10.2 SP2B installed on Gravity Hot Feed after the Vent Pipe on a specific outlet.

BALANCED FLOW SOLUTIONS

A single Shower Power Booster is sufficient for most installations. A good shower or tap mixer should be able to cope with pressure differentials of up to 4 to 1.

If your hot and cold supplies are both very low gravity pressure, or your mixer struggles to balance pressures, then you may need to install a pump on both the gravity hot and cold feeds. This will not only improve all water outlets, but will also keep the system balanced.

WHOLE HOUSE BALANCED SOLUTION

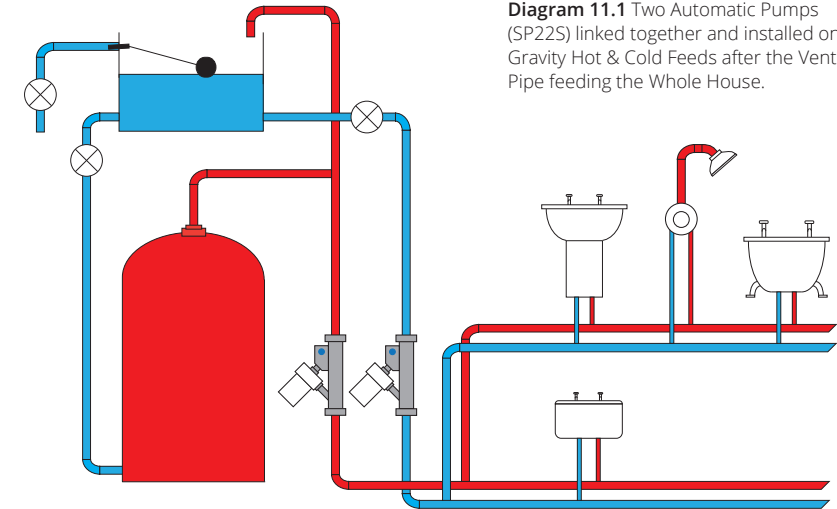

Diagram 11.1 Two Automatic Pumps (SP22S) linked together and installed on Gravity Hot & Cold Feeds after the Vent Pipe feeding the Whole House.

PROTECTED FLOW BALANCED SOLUTION

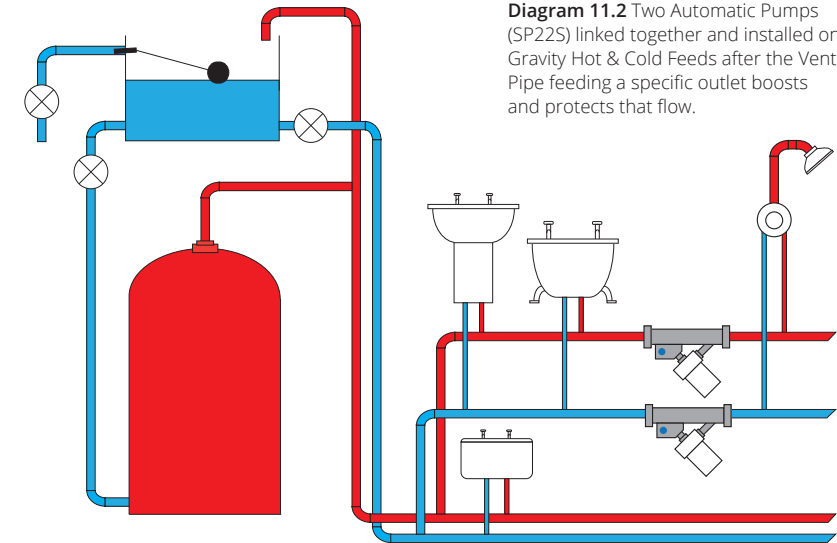

Diagram 11.2 Two Automatic Pumps (SP22S) linked together and installed on Gravity Hot & Cold Feeds after the Vent Pipe feeding a specific outlet boosts and protects that flow.

MIXED FLOW SOLUTION

If you have a gravity hot feed and a mains fed cold feed then you have a mixed system.

If your mains fed cold is higher than the gravity hot side and you are having issues due to this imbalance you will need an SP1U Shower Power Booster to give the gravity hot side an extra boost.

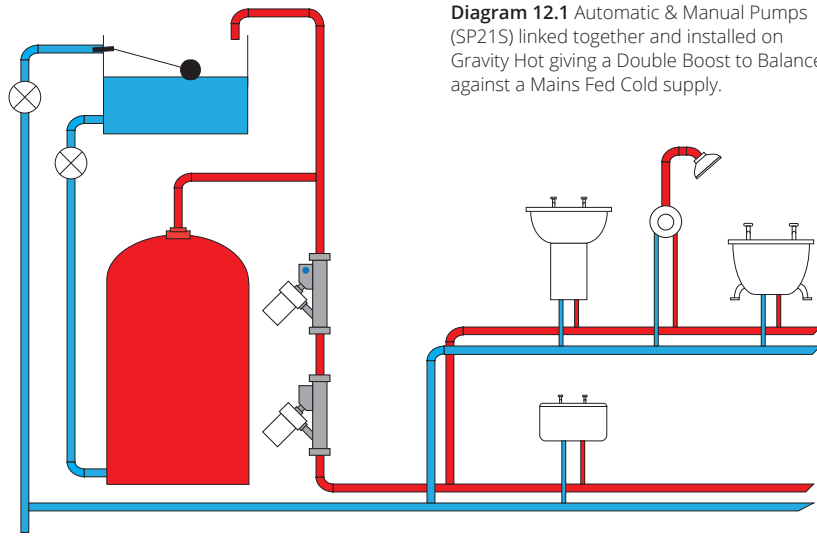
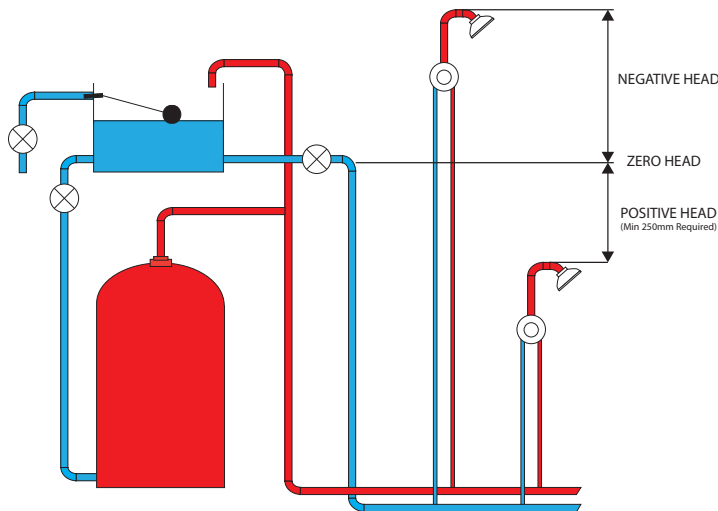

Diagram 12.1 Automatic & Manual Pumps (SP21S) linked together and installed on Gravity Hot giving a Double Boost to Balance against a Mains Fed Cold supply.

NEGATIVE HEAD & MANUAL SWITCHING

Diagram 12.2 Showing Negative, Positive & Zero head locations.



Manual Shower Power Boosters can be used for all Negative, Positive & Zero head applications. All Automatic Pumps can be used manually by plugging the transformer cable directly into the white motor. For dealing with negative head, zero head and close to zero head solutions, search on our website:

'Negative Head Shower Power Booster Solutions.'

COMBINATION BOILER SOLUTION

Combination boilers are fitting with a pressure sensor and if the pressure of the incoming mains cold water supply drops below 1.0 bar the gas is turned off. The Shower Power Booster can be legally fitted to the incoming mains cold supply to increase the pressure and flow rate to stop this from happening.

In most cases a double pump SP21S is enough to keep the boiler active by adding around 0.4 to 0.6 Bar to the pressure preventing the combination boiler from falling below 1 Bar.

Although the output of a combination boiler greatly exceeds the output of a Shower Power Booster you can still expect to protect flow rates of 6 litres a minute to showers and around 8.5 litres a minute to mixed flow to taps.

WHOLE HOUSE SOLUTION

Diagram 13.1 Automatic & Manual Pumps (SP21S) linked together and installed on Mains fed cold to a Combination Boiler.

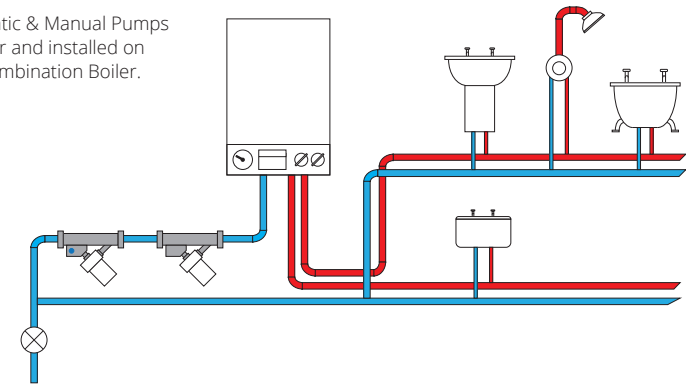

PROTECTED FLOW SOLUTION

A Shower Power Booster works on the hot side of any Combination Boiler to boost & protect a shower or tap. It increases the flow and gives that flow priority over other taps being used.

For demanding situations a pump on the hot and cold may be required (SP22S).

Diagram 13.2 Automatic Pump (SP2B) installed on the hot feed to a specific outlet.

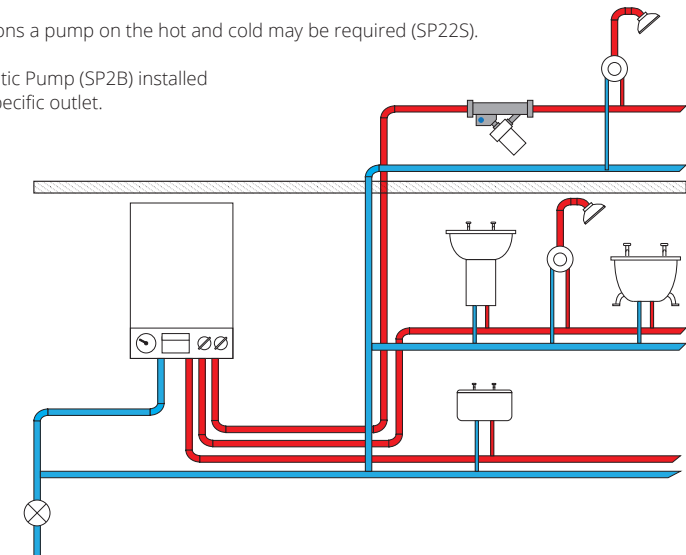

ELECTRIC SHOWER SOLUTION

All electric showers are fitted with a pressure sensor and if the pressure of the incoming mains cold water supply falls below 0.8 Bar, the electric shower will switch off heating elements and you will be left with a cold shower or boiling hot water. Adding a Shower Power Booster will increase the pressure and flow rates to stop this from happening. If your incoming cold water supply is exceptionally low then you may need to add a second pump to double boost.

Although a Shower Power Booster will keep your electric shower active, it is important to note that all electric showers are limited by the KW rate to the amount of water it can heat, we would therefore advise that you measure the flow rate at maximum hot (42°C) from your electric shower as you may already be getting the maximum flow rate from your electric shower:

7.5 KW	Electric Shower	3.5 litres a minute
9.8 KW	Electric Shower	4.7 litres a minute
12.5 KW	Electric Shower	6.0 litres a minute

Diagram 14.1 Automatic Pump (SP2B) installed on Mains fed cold to an Electric Shower.

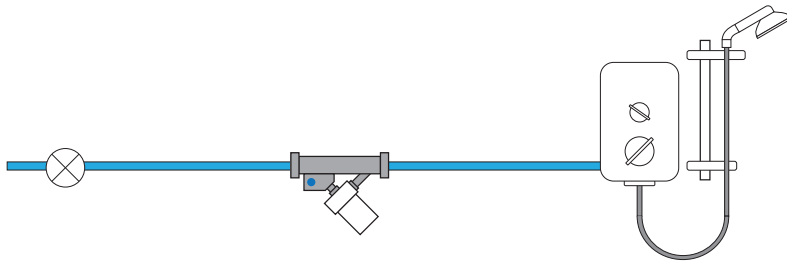

WRIGHTCHOICE RADIATOR FLOW BOOSTER

A radiator flow booster can drive water to or from a radiator or a group of radiators which are not getting hot. In many homes radiators do not get hot due to air locks, poor pipework, or due to being located some distance from the boiler. You can install the pump on either the flow or the return to the radiator(s). There are three versions of the pump.

Version 1 is based on an original SPB and fits 22mm and 15mm pipes.
Version 2 is 15mm and fits directly to the radiator.
Version 3 fits 10mm and 8mm pipes

Diagram 14.2 Shows an original SPB radiator flow booster boosting a single radiator

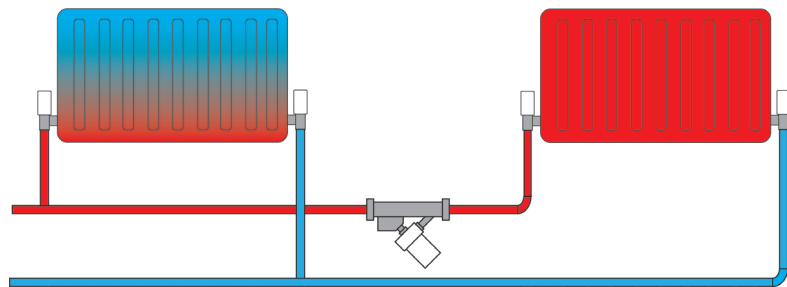

FLEXIBLE INSTALLATION

The Shower Power Booster can be installed anywhere within the house, including in a shower room and in the loft. Pumps do not cavitate or pull air in the vent pipe so you can install wherever is easiest to fit. If you are struggling to get two pumps close together or installing in different rooms you can still link them together using low voltage DC extension cables.

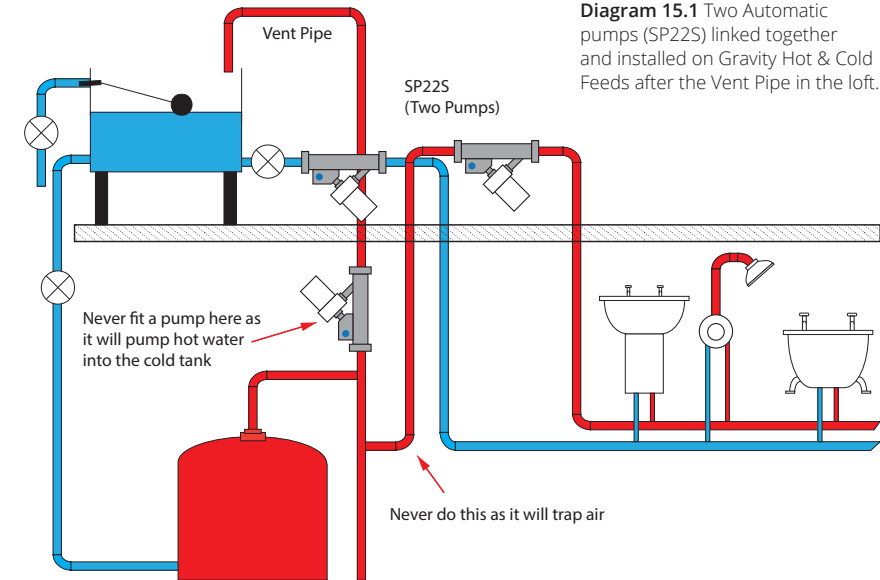
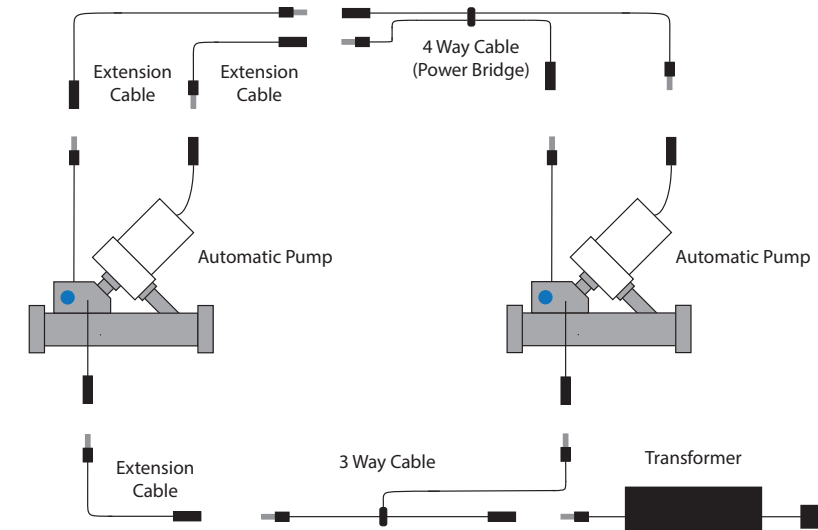

Diagram 15.1 Two Automatic pumps (SP22S) linked together and installed on Gravity Hot & Cold Feeds after the Vent Pipe in the loft.

WIRE DIAGRAM WITH EXTENSION CABLES



INSTALLATION TIPS - INSTALL PUMP AFTER THE VENT PIPE

The only place you cannot install a Shower Power Booster is before the vent pipe. Installing a pump before the vent pipe will result in you pumping hot water into your cold water tank and not to a tap or shower. Diagrams on the previous pages show where to install to boost either the whole house or a specific feed.

Before installing the pump you need to determine which pipe is heading to the cold water tank and which is heading for the outlet you want to boost. You can establish this by turning on the tap or shower you want to boost and feel which pipe gets hot. The vent pipe is the pipe going to the cold water tank and the hot water supply will be the hottest pipe.

You may find that the hottest pipe is the vent pipe heading up towards the cold water tank. If this is the case it means there is a gravity hot supply feeding off the vent pipe in another location, usually the loft. There is no problem installing in the loft, but make sure you fit the pump to the hottest pipe and the pipe which is only feeding the outlet you want to boost.

USING A SWIVEL CONNECTOR

A Swivel Connector allows you to connect the Shower Power Booster directly to 3/4" Male BSP Thread.



1. Take the bush from the reducing set supplied and insert into the body of the pump.
2. Place a washer on the bush and connect the round end of the swivel connector, creating a seal.
3. Place second washer inside the 3/4" swivel nut. The Shower Power Booster is ready to connect to a 3/4" Male BSP Thread.

USING A SLIP COUPLING

A 22mm or 15mm Slip Coupling can be used if you need some play on the pipes to fit the pump.



1. Cut the pipe either side of where you want to fit the pump
 2. Install the pump on the length of pipe you have removed.
 3. Reinstall the length of pipe you have removed.
- The coupling simply slips over the pipe so you can easily reconnect when the pump is installed.

USING 3 PIECE REDUCING SETS

3 Piece Reducing Sets are supplied with all Shower Power Boosters meaning you can easily install the pump on either 22mm or 15mm pipe.

When installing on 15mm pipe you need to use the 3 Piece Reducing Set:

1. Remove 22mm Nut & Olive.
2. Insert the Bush, thin end first.
3. Insert the 15mm Olive.
4. Place Ring on Olive, with the lip resting on the 15mm Olive.
5. Put the 22mm Nut back on and tighten.

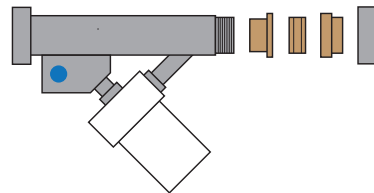

Bush

Olive

Ring

PUMP NOT KICKING IN?

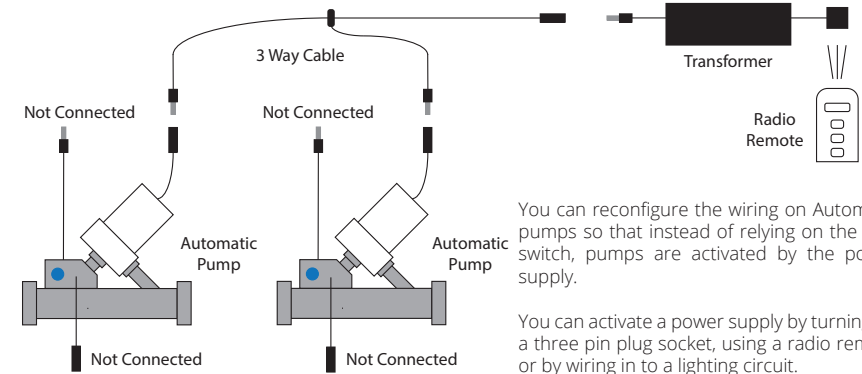

You can reconfigure the wiring on Automatic pumps so that instead of relying on the flow switch, pumps are activated by the power supply.

You can activate a power supply by turning on a three pin plug socket, using a radio remote or by wiring in to a lighting circuit.

PROBLEMS WITH AIR

Air trapped in the pipework between the hot water cylinder and the shower or tap can reduce the flow significantly. If the hot pipe near the cylinder rises into the loft, across and down to the outlet, then an 'inverted U' is created and a column of air will be trapped in the loft with no means of venting it. The solution is to tee the pipe into the vent pipe in the loft and fit the Shower Power Booster there. See Diagram 15.1 on page 15.

There are other pipe configurations that can trap air. Plug the transformer directly into the white motor and remove the shower head to maximise the flow. The increased flow may allow the water to push the air all the way to a shower hose or fully opened tap.

If the pump runs and you have a continuous flashing light, pauses with a constant blue light, then runs and the blue light starts flashing again - you have got trapped air.

INSUFFICIENT WATER REACHING THE PUMP

If there is insufficient water reaching the tap, then it will drain the water from the vent pipe until it runs out of water. When it has run out of water, the pump will spin quickly and the pumping efficiency will drop. This can allow the incoming water to 'catch up' and re-prime the pump - the pump commences to pump in water again, this can be identified by a lower tone from the pump. As soon as it exhausts the water supply the process repeats.

The fault can lie in not turning on the shut-off valve after the pump is fitted, a faulty shut-off valve, or sediment in the hot water cylinder which is blocking flow, or air in the pipe work between the cold tank and the hot water cylinder. To confirm this fault, allow a pipe to discharge water freely and note the maximum flow.

MIXER HUNTING (PULSING HOT AND COLD)?

The main reason for pulsing is either air or back pressures caused by a small bore shower hose or inefficient shower head. Take off the shower head and if this solves it try one of our shower heads and hoses.

Mixers react to hot water reaching the mixer by opening up the cold port. Some mixers react too slowly and open up the cold port too much and the hot port too much so it cycles hot and cold, high flow low flow. It might also be the anti scald feature on many mixers and the hot water you have is just too hot.

Turn the temperature on the hot down and it might just fix it or install a second automatic pump (SP2U) on the cold to balance pressures.

CAN'T FIND AN ANSWER TO YOUR PROBLEM?

Simply Google: *'ShowerPowerBooster fault finding'*



For more than 60 years Flowflex has been at the forefront of designing and engineering solutions for the heating and plumbing sector, delivering innovation and technical know-how to support contractors, consultants, installers and our distribution partners.

As a family business we pride ourselves in the integrity, quality and reliability we deliver through our products and people. With a strong heritage in British engineering and manufacturing we champion innovation and help to bring new and exciting solutions to the market.

Our vision is to be a world leader in engineering and manufacturing solutions for the heating and plumbing sector and beyond, including working in partnership with manufacturers across a variety of industries through our OEM solutions.



British Manufacturing and Engineering

Maintaining the highest quality in design, engineering and manufacture is a vital factor in the delivery of our fittings, valves and components. Operating on a six-acre site in the North of England, we ensure that we manufacture to the highest standards to produce outstanding products that are fit for purpose.

Over sixty years we have built the knowledge and expertise to develop superior engineering solutions for our customers and manufacture some of the most highly regarded non-ferrous plumbing fittings available on the market.

Our dedication and commitment to excellence in everything we do is evident in the loyalty of our customers and the reputation of our products.

www.flowflex.com



DON'T FORGET TO EXTEND YOUR WARRANTY!

For just £10 you can buy our 3 Year Ultimate Care Pack.

This can be purchased up to 12 months after your initial purchase.

CUSTOMER HELPLINE: +44 (0) 1928 620 099

www.showerpowerbooster.co.uk

Keep up to date with us on our social media channels
Please use the hashtag #getthepperfectshower and tag us.



WrightChoiceSPB



@showerpressure



showerpowerbooster



Trustpilot

For assistance please contact product experts at Flowflex who will be able to offer advice and help you with any issues you may have.

PHONE: +44 (0) 1298 77211

EMAIL: SPB@flowflex.com

FLOWFLEX OFFICE HOURS:

Monday to Thursday 09:00 to 17:00

Friday 09:00 to 16:00

Alternative & Out Of Hours contact details are displayed on our website:

www.showerpowerbooster.co.uk

SHOWER POWER BOOSTER

Invented by: Alan Wright BSc (Hons) CEng M.I.C.E



MANUFACTURED UNDER LICENCE IN THE UK
UK Patent Granted

spb_manual_10_2020